

# Conoflow

105 Commerce Way  
Westminster, SC 29693  
Tel: (864) 647-9521  
Fax: (864) 647-9574  
www.conoflow.com

## INSTRUCTION AND MAINTENANCE MANUAL

### HPNGV5 Series Compressed Natural Gas Vehicle Regulator

**WARNING:** These instructions must be read carefully prior to installation and system startup.

**INTRODUCTION:** The HPNGV5 Series regulator is a self-contained, pressure reducing regulator designed and qualified for 3000 and 3600 psig compressed natural gas (CNG) vehicular fuel systems. This regulator is factory calibrated and is not field adjustable. Various configurations of this regulator are available, based on the application needs. Consult the factory for part numbers, bowl kits, or configuration assistance.

**SYSTEM REQUIREMENTS:** High pressure CNG filtration (1 micron rating) is required to keep particulates in the gas stream from damaging the regulator and downstream components. The filter must be located upstream of the pressure regulator. Clean, burr free fittings and lines must be used to prevent particulate damage to the regulator.

**CONNECTIONS:** The HPNGV5 Series regulator is connected to the fuel system by gas inlet and outlet ports. These ports use CNG compliant SAE J1926 o-ring boss connections for 3/8" size tubing at the inlet connection (9/16-18 thread) and 1/2" size tubing at the outlet connection (3/4-16 thread). These connections are marked "INLET" and "OUTLET". The inlet and outlet lines must be sized for sufficient flow, and the outlet fitting must provide a 3/8" minimum bore for gas flow.

A coolant circulation bowl is provided which permits engine heat to warm the regulator and prevent internal icing of the regulator valve. Several coolant line connection sizes are available for reinforced rubber hose, which are secured with hose clamps.

Optional high pressure sensors are available (factory installed) to measure inlet pressure and provide a proportional DC voltage signal to measure tank pressure.

#### WARNING

Conoflow's products are designed and manufactured using materials and workmanship required to meet applicable standards. The use of these products should be confined to services specified and/or recommended in the Conoflow catalogs, instructions, or by Conoflow application engineers.

To avoid personal injury or equipment damage resulting from misuse or misapplication of a product, it is necessary to select the proper materials of construction and pressure-temperature ratings which are consistent with performance requirements.

An integral high pressure solenoid is available on the regulator to close off the flow of gas into the regulator when a voltage power signal is turned off.

A pressure regulator relief valve (PRRV) is provided. Standard regulator configurations discharge directly to the atmosphere. Capture pipe fittings are available for enclosed spaces or heavy duty vehicle applications.

**CAUTION:** The regulator's PRRV is a control and not a system safety device. It may not protect the regulator or fuel system under all possible / potential failure modes. A downstream safety valve or other failsafe strategy must be used to fully protect the fuel system and vehicle. The PRRV port must not be blocked by any obstruction.

**MOUNTING:** Two (2) M8 X 1.25 threaded holes are provided in the regulator to enable sturdy mounting. The regulator may be oriented in any direction; however, Conoflow recommends that the gas ports are horizontally oriented to minimize exposure of the gas lines, and prevent collection of oil and moisture in the downstream line. The regulator must be rigidly mounted on the vehicle, and protected from impact of road debris.

**WARNING:** Do not mount the regulator by gas or coolant connections only. This regulator must be securely mounted by M8 x 1.25 bolts.

Please refer to the interface drawings for mounting dimensions, connection identification and connection details.

## SPECIFICATIONS:

Service Pressure: 3600 psig  
(248 bar)

Outlet Pressure: Factory preset – see regulator label

Outlet Pressure Variation in Service: -10 to +18 psi from labeled setting throughout the range of operating inlet pressure, temperature and gas flow. See flow performance graph to see effect of inlet pressure and gas flow changes to the delivery pressure.

Temperature Range: -40° F to 250° F  
(-40 °C to 120 °C)

Solenoid: Normally closed,  
Pilot operated  
12 or 24 VDC systems  
2 Amp max draw.  
5A line fuse recommended  
Amp Superseal 1.5

Sensor: 5000 psi span  
5 +/- 0.25 VDC Excitement  
Ratiometric DC Output  
Packard Metripak 150  
(3 conductor)

Connection Torques: Inlet (SAE-6): 27 ft-lb  
Outlet (SAE-8): 42 ft-lb  
Mounting Bolts: 15 ft-lb

Flow Capacity: Up to 175 lb/hr of CNG (Flow varies by application – consult the factory for data)

PRRV Opening: 200 +/- 40 psig (optional)  
Pressure 270 +/- 60 psig (optional)  
350 +/- 60 psig (optional)

PRRV Type: Reseatable

Approval: ECE R110

## MATERIALS OF CONSTRUCTION:

Body: 6061-T6 Aluminum  
Bonnet: 6061-T6 Aluminum  
Diaphragm / Seals: Fluorosilicone / HNBR rubber  
Valve Trim: Stainless Steel / Polyimide

**NOTE: This regulator has been tested and certified for safe and reliable service in Natural Gas Vehicles. There are significant potential hazards associated with CNG which the user and / or installer must be aware of when using this product.**

**CAUTION: Install the regulator in accordance with NFPA 52, CAN/CGA-B149.4 and other codes and standards applicable to the jurisdiction of installation and service.**

**WARNING: CNG can cause damage and / or injury due to very high pressure, flammability, and extreme cold during expansion. Suitable safeguards must be employed during installation, commissioning and service to prevent harm to personnel and property.**

## PRINCIPLE OF OPERATION

The HPNGV5 series is a mechanical pressure regulator. The main valve, within the regulator, is coupled to a diaphragm assembly. A spring preload against the diaphragm assembly pushes the main valve open. As gas flows through the regulator, downstream pressure will increase and push the diaphragm assembly against the spring load, closing the main valve. The diaphragm and valve are dynamic, and will seek equilibrium so the inlet pressure is reduced and regulated throughout the useful range of gas flow.

When the solenoid valve is energized, the pilot valve will immediately open when current flows through the solenoid coil. Once pressure builds in the pilot valve, the main orifice of the solenoid valve will open and permit full flow through the regulator.

When the engine is shut off, gas flow through the regulator ceases. The solenoid valve closes, and the regulator's main valve is pulled closed by the diaphragm assembly. Downstream pressure will be trapped in the low pressure side of the fuel system.

An engine coolant circulation bowl is fitted over the end of the regulator to provide engine heat to the regulator valve and the gas. This heat prevents ice buildup in the regulator, which could reduce performance and regulator life.

## INSTALLATION GUIDELINES

**WARNING: Inspect the unit after unpacking. If the unit appears to be damaged do not place in service.**

1. Plan the installation for the best combination of accessibility, protection from engine exhaust heat, mechanical vibration or impact, and suitable mounting orientation.

*SEE SYSTEM IMPERATIVES ON PAGES 3 and 4*

2. A suitable lubricant (oil, synthetic grease, etc) should be applied to the o-ring of the fitting, prior to installation, to help the o-ring seat and seal.

**Do not use silicon grease** – silicon may poison the oxygen sensor in some vehicles.

3. If the regulator is equipped with the optional PRRV capture pipe, connect the system fitting to the capture pipe.

**NOTE:** *The optional 1/4" NPT PRRV Capture Pipe fitting must be wrench supported during connection, to prevent shearing.*

4. Attach regulator securely to vehicle, using two M8 x 1.25 mounting bolts (not included).
5. Connect the inlet, outlet, and coolant connections. Assure any entrapped air in regulator is fully purged from coolant bowl. As applicable, connect the PRRV, sensor and solenoid.  
See pages 6-8 for connection details
6. Pressurize the system and perform a leak test of gas connections with liquid leak detection solution or soapy water.
7. Energize the solenoid circuit to admit gas through the regulator and verify the outlet gas connection is leak tight.

## SYSTEM IMPERATIVES

Imperatives are those conditions, when violated, can cause regulator or system failure and an increased risk of gas release. The following imperatives are listed with potential risks to assist the fuel system integrator with system design failure modes and effects analysis.

### 1. Upstream Coalescing Filter

This pressure regulator is equipped with a coarse internal filter. A larger, finer grade filter must be installed upstream of the regulator. This filter should be sized for suitable flow capacity. The purpose of this filter is to prevent excessive moisture and compressor oil droplets, or particulate contaminants from entering the regulator. A one (1) micron filter will sufficiently protect the regulator from particulate contamination damage.

### 2. Sealants

Sealants are not required for the SAE o-ring boss gas connections. The use of sealants as a fitting leakage preventive measure can contaminate the internal passages and valve(s) in the regulator and cause malfunction. *Sealant use in these connections will void the factory warranty.*

### 3. Inlet / Outlet Fittings and Fuel Lines

The regulator has been designed for SAE o-ring boss fittings which correspond to 3/8 inch OD tubing (SAE-6) for the inlet, and 1/2 inch OD tubing (SAE-8) for the outlet. These are the recommended line sizes.

Excessively large line or fitting diameters may induce instability of the delivery pressure. The minimum bore of the fittings must be a minimum of 0.27 inch (6.8 mm) for the SAE-6 inlet fitting and 0.37 inch (9.4 mm) for the SAE-8 outlet fitting. Fittings may be of type SAE J1926/2 or SAE J1926/3.

Tubing must be clean and free of burrs, which could contaminate the regulator or fuel system. The outlet line should not be run upward from the regulator outlet port, due to the potential for excessive oil and condensate collection. A level or downward run is preferred to prevent collection.

### 4. Mounted Orientation

The regulator should not be mounted with the outlet fitting facing upward or the bonnet (spring cover) downward. These orientations permit oil condensate from fuel carryover to collect in the regulator.

### 5. Downstream Relief Valve

Although the regulator is equipped with a pressure regulator relief device (PRRV), a high flow relief valve or other protective strategy must be installed between the regulator outlet and the remainder of the fuel system. The regulator's PRRV is not a high flow device and may not protect the regulator or fuel system in case of sudden failure.

### 6. Engine Coolant

The expansion of high pressure gas to low pressure creates a significant temperature drop. To prevent moisture from freezing inside the regulator and creating a blockage, heated engine coolant must be circulated within the regulator. The regulator is equipped with a coolant bowl for this purpose.

Engine coolant must be maintained for at least -40° antifreeze protection. If the coolant were to freeze in the regulator, for any reason, the coolant containment integrity may be compromised.

Phosphate based coolants may damage the coolant seals in this product. Glycol based coolants are recommended.

Suggested *minimum* flow: Engine idle 1-2 lpm, Moderate power 3-6 lpm, depending on engine size.

### 7. Excessive Heat

The regulator is designed for safe and reliable operation within a temperature range of -40 to 250 °F.

Temperatures above 275 °F can quickly damage internal seals and reduce the useful life of the pressure regulator. If the regulator is located in an area with the potential for high temperature (such as radiated energy from exhaust system components, etc), suitable heat shields must be employed.

#### 8. Fitting Torque

The correct assembly torque for the inlet (SAE-6) fitting is 27 ft-lb. The correct assembly torque for the outlet (SAE-8) fitting is 42 ft-lb. For optional gauge ports, the correct assembly torque for an SAE-3 fitting is 6 ft-lb. The correct assembly torque for an SAE-4 fitting is 10 ft-lb.

Inadequate torque could allow the fitting to loosen in service and leak. Excessive torque could weaken or damage the threads. Use correct tools and exercise caution when installing or connecting fittings to prevent injury.

*Gas connections (except the PRRV) are sealed with an o-ring. Use of thread sealant will void the warranty.*

#### 9. Submergence in water

Except for bonnet bias models, the regulator uses an atmospheric reference hole in the bonnet to sense ambient pressure. This hole is "filled" with a porous hydrophobic plastic plug to prevent water intrusion from splashing, wash down, etc. This plug may not prevent water intrusion if the regulator were to be submerged in water. For this reason, the regulator should not be mounted low in a vehicle which would normally cross flooded roads, etc.

#### 10. Chemicals in Fuel

The regulator is tolerant to substances that occur in compressed natural gas, including most CNG compressor oils, *however ITT should be contacted regarding specific compressor oils or other fuel borne substances.*

#### 11. Rapid or Frequent Fuel System Decompression

CNG Fuel systems should not be rapidly or frequently decompressed of gas. Doing so will cause gas absorbed in non-metallic materials to attempt to escape those materials, decreasing the useful life of the regulator.

#### 12. Salt and/or Dirt Buildup

Excessive road salt and/or road dirt buildup will accelerate moisture attack and subsequent corrosion of the regulator at the solenoid and/or gas connections. Accelerated corrosion leads to premature external gas leakage failure.

The regulator must be installed in a manner which provides reasonable protection from road salt and debris accumulation, to reduce the risks of accelerated corrosion.

#### 13. Pressure Adjustment

This pressure regulator is factory calibrated and tested. Removing the tamper evident cover from the adjustment will void the warranty.

#### 14. Fuel System Validation

This fuel pressure regulator will dynamically respond to the CNG fuel system. In new applications it is the responsibility of the customer to validate the performance of the fuel system with this regulator. ITT cannot be responsible for the suitability of this fuel pressure regulator in every application.

#### 15. Fuel Type / Quality

This fuel pressure regulator is designed and qualified for CNG fuel. RNG (Renewable Natural Gas) is acceptable, provided it meets the quality guidelines of the American Biogas Council (ABC) for CNG fuel. This fuel pressure regulator is not for use with raw Biogas.

**CAUTION: Stored spring compression within the regulator can be unexpectedly released if the regulator is disassembled.**

**As part of your fuel system and vehicle protection review, ITT recommends the incorporation of a system warning label that clearly advises maintenance technicians to 1) NOT DISABLE any automatic upstream isolation valves and to 2) CLOSE upstream isolation valves and bleed system pressure prior to servicing.**

#### TROUBLESHOOTING:

1. Sometimes, the regulator does not provide sufficient fuel pressure to the engine's fuel system.

*This regulator uses a pilot operated solenoid valve. In the event there is downstream leakage when the vehicle is not operating, the flow from the pilot valve may not be sufficient to fully charge the fuel system if the engine is started and loaded quickly. This phenomenon is amplified at low tank pressure.*

*A time dwell between energizing the solenoid and starting the engine will provide sufficient time for the pilot flow to charge the fuel system and permit the high flow orifice of the solenoid valve to open fully. When the high flow orifice opens, the solenoid will emit an audible "click" noise.*

2. The regulator “pops” when I turn on ignition key and activate solenoid valve(s).

*This is caused by downstream leakage, or regulator damage caused by particulates. If the downstream pressure bleeds down, the inrush of high pressure CNG can cause the regulator outlet pressure to overshoot the PRRV opening pressure and discharge excessive pressure from the line. Correct / repair any downstream leakage to prevent system depressurization when the vehicle is not operating.*

3. After driving the vehicle, frost is visible on the exterior of the regulator and outlet fuel line.

*This is common for duty cycles when there is a significant amount of gas flow. Although the regulator is heated with engine coolant, this energy is used to protect the regulator’s valve, and is not sufficient to heat the fuel sufficiently. As the fuel flows to the engine, it will absorb heat from the outlet fuel line. Some heavy duty applications may require a downstream heat exchanger.*

*In some installations, air can become trapped in the regulator coolant circuit, and must be vacuum purged or flushed out over time with coolant flow.*

4. When leak testing the system, our gas detector shows leakage from the white plug on the regulator.

*A very slight amount of gas permeates from the regulator, and this is normal. A gas detector can show leakage “false alarms”, as this instrument is very sensitive.*

*ITT recommends using commercially available leak detection solution, or soapy water, to leak test the fuel system.*

5. Loud noises are coming from the regulator.

*Noisy operation can be caused by system interaction issues. If fittings or line sizes other than those recommended are used, it may cause internal oscillation which can create noises ranging from a buzzing sound to a rapid internal knocking sound. Very large outlet lines may cause pressure spikes during changes in gas flow.*

*In rare instances, the HPNGV5 regulator resonant frequency (typically around 350 Hz) will match the fuel system’s resonant frequency. Changing the size of the outlet line will usually solve this issue.*

## MAINTENANCE

**WARNING: Bleed system pressure prior to removal and servicing of this pressure regulator.**

Properly designed and maintained fuel systems will increase the reliability and life of this pressure regulator.

1. Follow vehicle guidelines for fuel system filter maintenance and engine coolant maintenance.
2. Keep the exterior of the regulator clean to reduce buildup. Dirt or salt buildup can attract moisture and accelerate corrosion. Protective sprays may be used in areas where dissimilar metals (solenoid, gas connections, etc) meet.
3. Schedule leak testing to verify regulator gas containment. Leakage is the result of wear and aging; it is the inevitable failure mode of the pressure regulator.

### Regulator Part Number Breakdown (CED Code)

Character Position	Option	
1-6	<u>HPNGV5 - Base Product Family</u>	0 = SAE-4 Outlet Pressure Gauge Port (Not Available with Solenoid) N = No Pressure Gauge Port
7	<u>Bonnet Options</u> S = Std Bonnet (atmospheric Reference) C = Captured Bonnet, w/ 3/16" Hose Barb E = Captured Bonnet, w/ 1/4" Tubing Swivel Elbow	11 <u>Pressure Sensor (Factory Installed and Tested Requires SAE-3 Gauge Port)</u> N = No Pressure Sensor P = 0.25 to 4.75 Volt Output (over 5000 psi range) W = 0.50 to 4.50 Volt Output (over 5000 psi range)
8-9	<u>Inlet Solenoid Valve Options</u> NA = No Inlet Solenoid Valve 12 = Std Capacity 12 volt solenoid valve 24 = Std Capacity 24 volt solenoid valve 1X = High Capacity 12 volt solenoid valve 2X = High Capacity 24 volt solenoid valve	12 <u>Outlet Side Pressure Regulator Relief Valve (PRRV)</u> A = 200 PSI B = 270 PSI C = 350 PSI
10	<u>Gauge Port Options</u> 3 = SAE-3 Inlet Pressure Gauge Port 4 = SAE-4 Inlet Pressure Gauge Port	13 <u>PRRV (Relief Valve) Discharge Connection</u> P = 1/4" NPT Male Pipe Connection T = 1/2" Tube Stub Connection (for std tube fittings) X = Discharge to Atmosphere (no connection)

- 14 Coolant Circulation Bowl  
 H = Cast Aluminum bowl with 3/8" side ports  
 (ports positioned towards outlet side)  
 L = Machined Aluminum bowl with 1/2" NPT  
 M = Machined Aluminum bowl with 3/8" NPT  
 NOTE: Machined bowls have ports on bottom
- 15 Coolant Connections  
 N = None  
 3 = 3/8" straight hose connections
- 4 = 1/2" straight hose connections  
 5 = 5/8" straight hose connections  
 6 = 3/4" straight hose connections
- A = 3/8" hose elbows  
 B = 1/2" hose elbows
- 16-18 Factory preset Outlet Pressure in psi  
(at Full Tank / Idle Flow Conditions)

**CAUTION: Regulator is factory preset. Changing the pressure setting can cause unexpected and/or potentially hazardous operation. Removal of the tamper proof cover will void the warranty.**

**CONNECTION IDENTIFICATION AND TYPICAL GEOMETRY**  
**HPNGV5SX123PAXH3\_\_\_ CONFIGURATION SHOWN – DIMENSIONS IN MILLIMETER (INCH)**

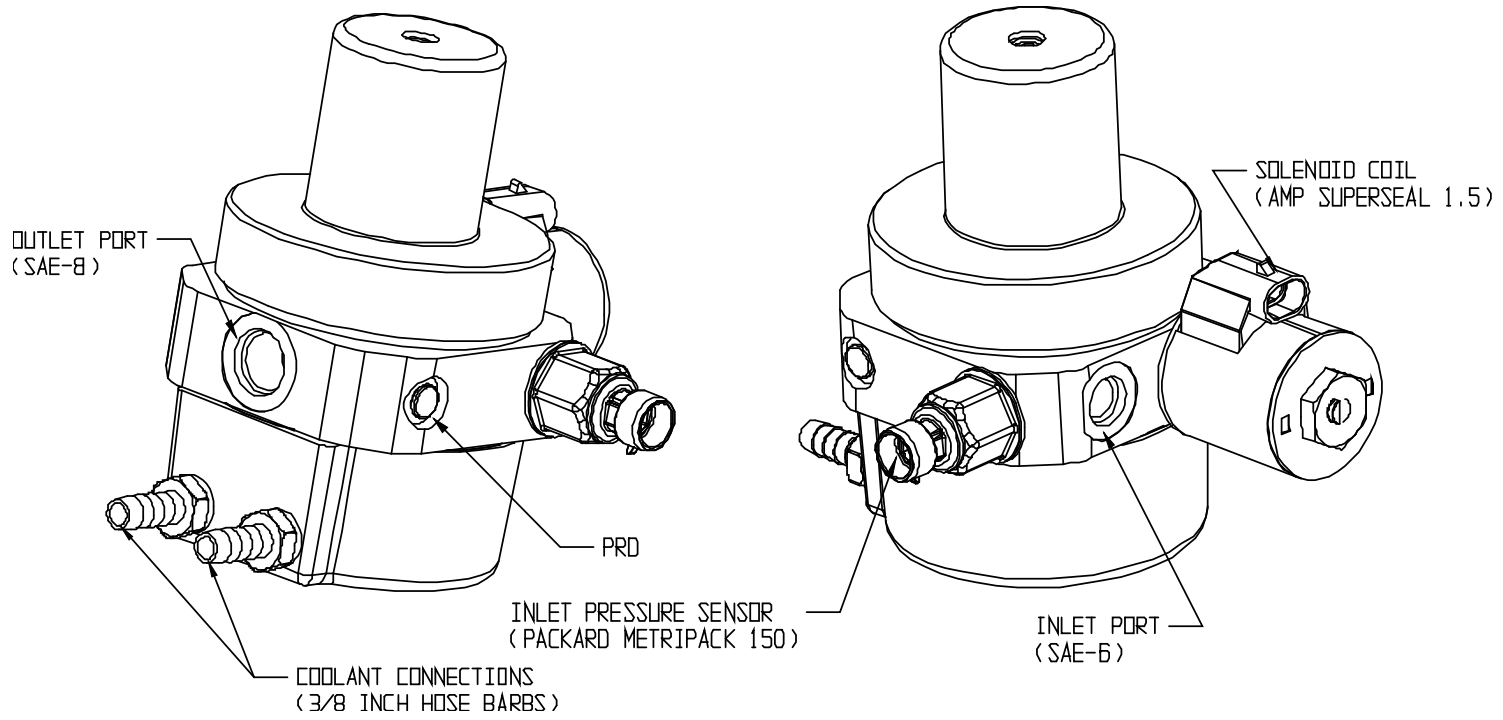

**Interface Views – Option (Code)**

- Standard Bonnet (S)**
- Standard capacity solenoid in 12 Volt (12)**
- SAE-3 Inlet Sensor Port (3)**
- 0.25 to 4.75 Volt Pressure Sensor (P)**
- Discharge to Atmosphere PRRV (X)**
- Cast Aluminum Coolant Bowl with 3/8" NPT Side Ports (H)**
- 3/8" Straight Hose Connections installed in Coolant Bowl (3)**

THIS INFORMATION IS SUBJECT TO THE CONTROLS OF THE EXPORT ADMINISTRATION REGULATIONS (EAR). THIS INFORMATION SHALL NOT BE PROVIDED TO NON-U.S. PERSONS OR TRANSFERRED BY ANY MEANS TO ANY LOCATION OUTSIDE THE UNITED STATES CONTRARY TO THE REQUIREMENTS OF THE EAR.

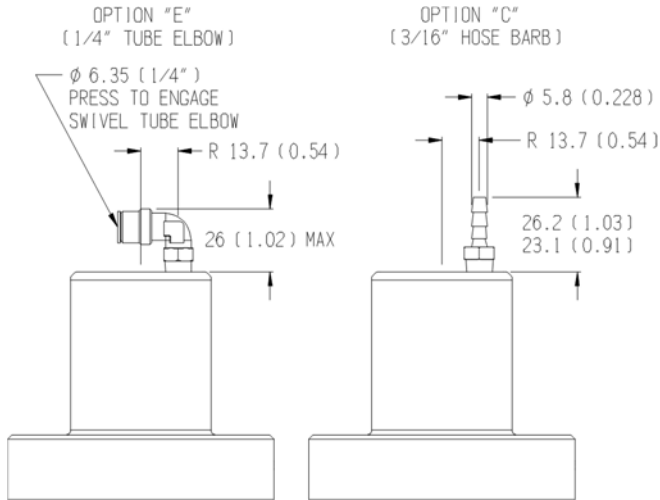

OPTIONAL BONNET CONNECTIONS

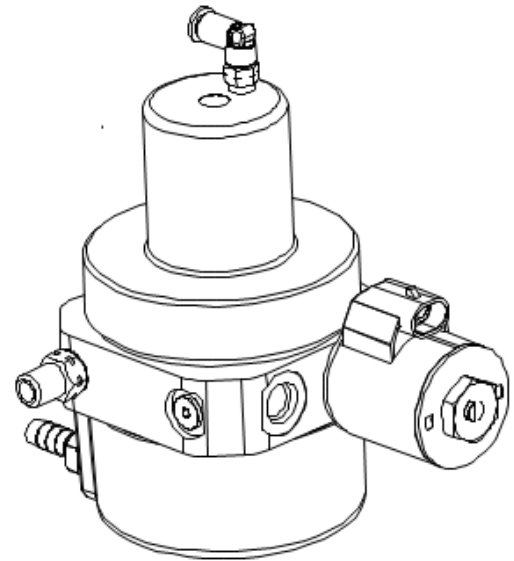

REGULATOR SHOWN WITH STANDARD CAPACITY SOLENOID VALVE, SWIVEL BONNET ELBOW CAPTURE PORT, 1/4" PRRV CAPTURE PIPE.

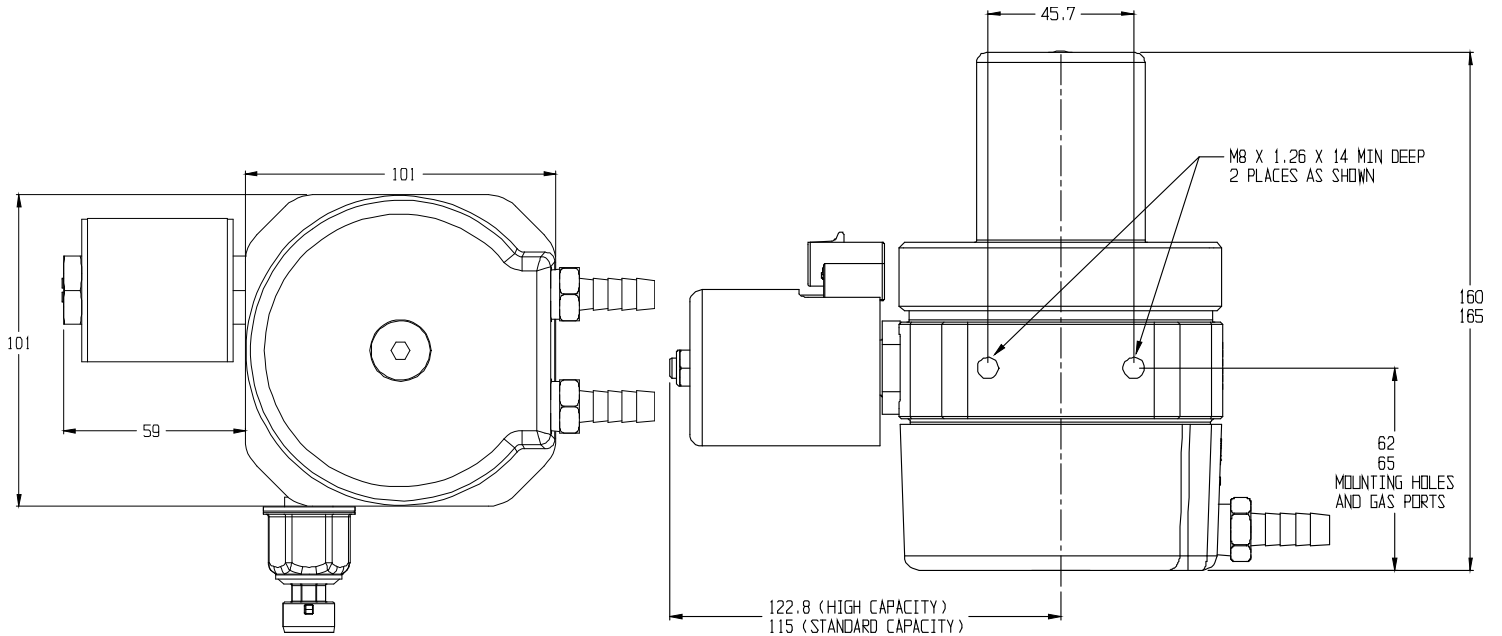

BODY PROFILE/ BOTTOM VIEW  
STANDARD CAPACITY SOLENOID,  
"H" COOLANT BOWL OPTIONS

MOUNTING BOLT HOLES, PORT HEIGHT  
AND OVERALL LENGTH OF REGULATOR  
(SHOWN WITH HIGH CAPACITY SOLENOID VALVE)

## ELECTRICAL INTERFACE DATA

Solenoid valve electrical mating connector part numbers:

Housing: Amp / Tyco Electronics 282080-X (X designates color)

Contacts: Amp / Tyco Electronics 282110 female connector

Wire seal: Amp / Tyco Electronics 281934-2

Suggested wire gauge: 18 gauge

**WARNING: Circuit protection with a 5A maximum current is required for solenoid valve wiring.**

OEM pressure sensor electrical mating connector part numbers:

Housing: Delphi 12065287 (with included weather seal)

Contacts: Delphi 12110236

Suggested wire gauge: 18 gauge

**WARNING: Circuit protection with a 1A maximum current is required for sensor power lead wiring.**

The components above may be substituted for functional equivalents. Other contacts and seals are available for alternative wire sizes. Consult OEM connector supplier data.

When selecting alternatives, the following guidelines must be considered:

- Mating terminals must be tin-plated. Gold-plated connectors may cause galvanic corrosion of the connection interface and ultimately prevent the solenoid valve and/or pressure sensor from operating.
- Weather seals must be used between the connector bodies, and at the cable ports.

Sensor polarity / pin connection diagram:

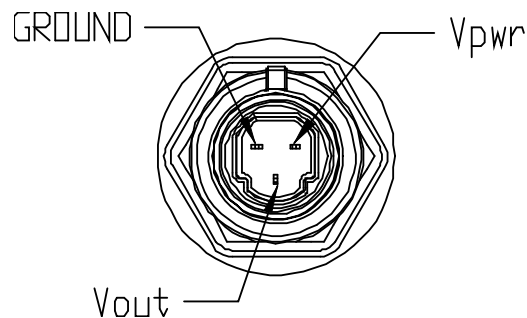

$V_{pwr} = 5.0 \pm 0.25 \text{ VDC}$

$V_{out}$  = Ratiometric output (product dependent)

Ground = Common ground

There are no polarity requirements for the solenoid valve electrical connection.