



ITT

Enidine / Conoflow
105 Commerce Way
Westminster, SC 29693
Tel: (864) 647-9521
Fax: (864) 647-9574

Engineered for life

INSTRUCTION AND MAINTENANCE MANUAL **GH21XT/GH41XT Fixed Differential Pressure** **Regulator**

WARNING: These instructions must be read carefully prior to installation and system startup.

INTRODUCTION

The ITT Conoflow GH21 & GH41 XT fixed differential pressure regulators are used to maintain a constant pressure differential across a variable or fixed orifice, providing a constant flow rate regardless of variations in upstream or downstream pressure. Various configurations of this regulator are available, based on the needs of the application.

The GH21 & GH41 XT maintains a fixed differential of approximately 3 psi (21 kPa) across the bonnet and outlet connection. Adjustment of the flow rate is made downstream of the system. These units are normally

PRINCIPLE OF OPERATION

The GH21 & GH41 XT fixed differential pressure regulator is used to maintain a fixed differential pressure across a needle valve, downstream from the regulator.

The spring in the bonnet of the regulator exerts a force on the diaphragm assembly which requires approximately 3 PSI (21 kPa) underneath the diaphragm to balance with zero signal pressure. As signal pressure is applied to the bonnet connection, an increase in output pressure is required to keep the forces on the diaphragm assembly balanced.

In equilibrium, the force due to the output pressure will be equal to the force from the spring plus the force due to the signal pressure. Since the spring force is equivalent to 3 PSI (21 kPa), the output pressure will always be a 3 PSI (21 kPa) *greater* than the signal pressure.

If the output pressure drops below the equilibrium point, there is a net downward force on the diaphragm

WARNING

Conoflow's products are designed and manufactured using materials and workmanship required to meet applicable standards. The use of these products should be confined to services specified and/or recommended in the Conoflow catalogs, instructions, or by Conoflow application engineers.

To avoid personal injury or equipment damage resulting from misuse or misapplication of a product, it is necessary to select the proper materials of construction and pressure-temperature ratings which are consistent with performance requirements.

assembly. This force causes the nozzle plug to open allowing supply pressure to flow downstream until the output pressure returns to its equilibrium value.

INSTALLATION:

WARNING: The Maximum Inlet (supply) Pressure is 200 psi (1379 kPa) for the standard brass body model or 300 psi (2068 kPa) for the optional stainless steel model.

The regulator has three (3) ¼ npt connections. The inlet connection is marked "IN". ***It is recommended that a filtered supply media is used.***

All connections should be checked for leakage after installation.

SPECIFICATIONS:

Maximum Inlet Pressure (brass): 200 psi (1379 kPa)
(stainless steel): 300 psi (2068 kPa)

Maximum Signal (bonnet) Pressure: 100 psig (690 kPa)

Fixed Differential: Outlet shall fall between 2.5 and 3.5 psi above signal pressure when evaluated at a supply pressure 40 psi greater than signal pressure.

Connections: 1/4" NPT (Inlet / Outlet)
1/4" NPT (Bonnet Signal Pressure)

Temperature Range: -20 °F to 150 °F

Catalog Part Number Breakdown (Control Engineering Data or CED Codes) for the GH21XT Series Regulator

Control Engineering Data is intended to provide a single source from which one can determine, in detail, the full scope of the product line. In addition to materials of construction and diaphragm selection, it also provides all necessary data, regarding adjustment options and range selections. Control Engineering Data also provides a means of communicating, by way of a code number, which is fully descriptive of the product selection.

NOTE: 1. Catalog numbers as received must contain eight-eleven (8-11) characters.

1-4 Model	GH21 or GH41 = Regulator – Differential
5 Operational Features	X = Standard - Unless Option Code is Specified
6 Bonnet Options	T = Threaded Bonnet - (Standard)
7 Mounting Options	X = Absence of Specification – Standard
8 Diaphragm Selections	M = Buna "N" (No Bleed, No Relief) K = Teflon (Sandwich Type - No Bleed, No Relief) (Stainless Steel Configuration)
9 Seat Selections	X = Standard - Unless option code is specified
10 Material Options	K = Stainless Steel Construction (302/303 Stainless Steel Internals) S = Stainless Steel Construction (316 Stainless Steel Internals) X = Standard - Unless option code is specified.
11 Cleaning Options	A = Cleaned for Oxygen Service X = Standard level cleanliness

When replacement parts are required, please contact the factory with the full model number and serial number of the regulator.

MAINTENANCE

CAUTION: Remove air supply pressure and thoroughly vent the inlet and outlet pressure prior to performing maintenance.

Periodic replacement of the diaphragm assembly and nozzle assembly is recommended for services where the unit is on-stream continuously and where consistent, high accuracy regulation is required. The frequency of replacement is dependent on the nature of the application and can be affected by the cleanliness of the media, the temperature and humidity of the environment, the rate of flow, and other factors.

To replace the diaphragm assembly, loosen and remove the fillister head machine screws and lift off bonnet and

differential pressure spring. Remove the diaphragm assembly. Place the new diaphragm assembly on the bonnet, with the diaphragm plate and staked side face upward (away from the body). Place the differential spring over the diaphragm assembly then secure the bonnet with the fillister head machine screws tightened to 30 in-lb. .

To replace the nozzle assembly, disassemble the regulator as previously described, then remove the baffle plate and the nozzle assembly. Use a 5/8" socket wrench to remove and install the nozzle assembly.

The metal nozzle assembly may be cleaned in solvent, or replaced. When replacing the nozzle assembly, the nozzle is installed with 80 in-lb assembly torque. Incorrect torque can create leakage and damage the nozzle assembly.

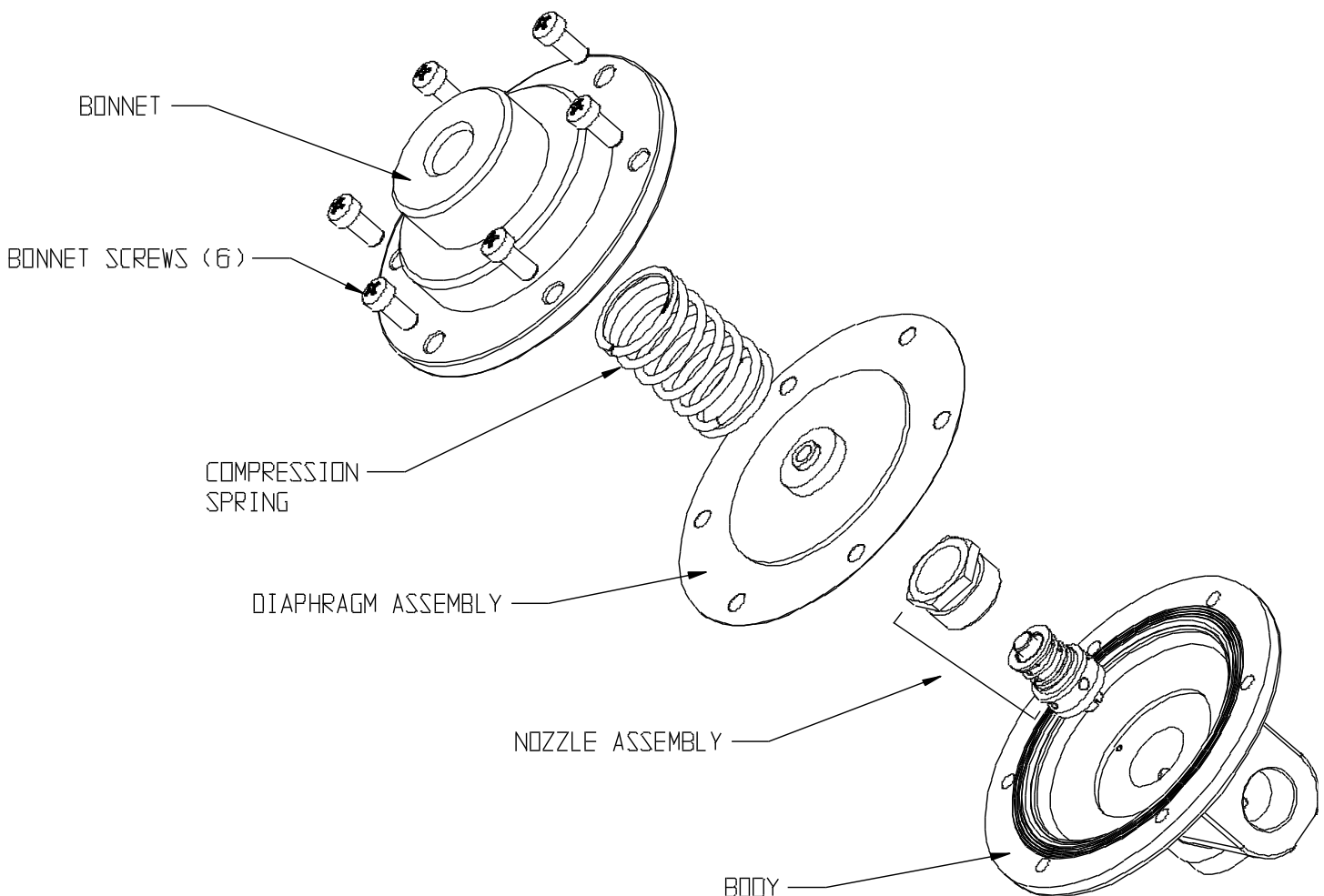

This page intentionally left blank for user notes